

AMP Sydney Cove Case Study – Renovation of an Induction System with Active Chilled Beams

Overview

The AMP Sydney Cove project was a renovation of a 25 story multi-tenant office building in Sydney, Australia. Twenty-one of the building's floors had floor-mounted induction units along the perimeter on all four exposures. The interior zones were served by a separate single duct VAV system. Each of the floors had approximately 11,800 sq. ft. of rentable area (248,000 sq. ft. total).

Over time the building's cooling loads had increased due to more internal equipment heat gains and higher occupancies. The perimeter sensible cooling loads had increased to 229 Mbh per floor (4,810 Mbh total).

The existing floor-mounted induction units were not capable of delivering the higher cooling capacities or air quantities required. The existing induction system was replaced with a ceiling-mounted active chilled beam system providing the higher cooling capacities required.



Perimeter System Design Issues

- The owner wanted to eliminate the floor-mounted units and find a HVAC system solution from the ceiling.
- There was insufficient refrigeration and pumping capacity to satisfy the new cooling loads which required the installation of new chillers and pumps.
- The primary airflow and pressure were limited by the existing central air handlers and ductwork, and an important design objective was to use the existing air handlers, vertical risers and ductwork in the new perimeter system.
- The existing induction system utilized a primary air temperature of 55 °F and a secondary water temperature of 50 °F. At this water temperature some condensation occurred within the existing induction units, which was piped to a drain.
- Space above the suspended ceiling was adequate to accommodate ceiling-mounted units.
- The owner was interested in energy savings and reductions in noise levels.

Design Solution

Dadanco was able to offer a new active chilled beam perimeter system design that met the design objectives.

- The take-offs at each floor off the vertical risers and the secondary chilled water piping were relocated from the floor to the ceiling.
- (1,095) ACB35 concealed ceiling-mounted active chilled beams were installed in place of the existing floor-mounted induction units. The new ACB units were sized at the same primary airflows as the existing induction units, but at 0.5-1.0" w.c. lower inlet static pressures and at a higher 55 °F secondary chilled water temperature.
- New drives were installed on the existing central air handlers to provide the primary airflow at the new lower operating pressure.

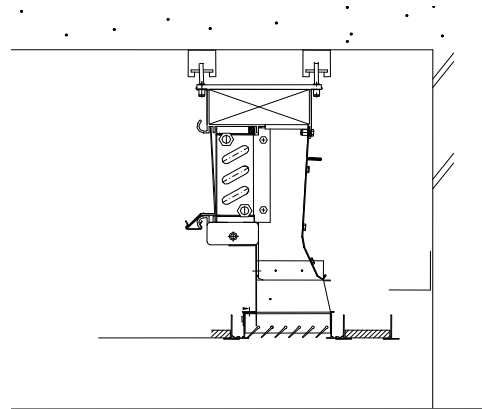

Benefits

- Cooling capacities were increased in the perimeter zones.
- Fan energy consumption was reduced due to the lower fan operating pressure.
- Pump energy consumption increased slightly due to the higher secondary water flows.
- Floor space was gained, appearances improved and the office space was upgraded to premium grade with the removal of the floor-mounted induction units and installation of the ceiling-mounted Active Chilled Beams.
- Costs were avoided as there was no need to purchase new custom enclosures which would have been required if the existing units had been replaced with floor-mounted units.
- Noise levels were reduced through the performance of DADANCO's patented nozzle technology and lower static pressures.

260 North Elm Street Westfield, MA 01085
Ph: (413) 564 – 5657
Fax: (413) 568 – 2969

www.dadanco.com
info@dadanco.com